

Keep these instructions in a safe place!  
After installation of the tubular drive attach these instructions to the cable for the electrician.

**Device functions:**

- Blind protection (torque limiting)
- Commissioning the drive with the assembly cable

**As-delivered condition** (commissioning mode)

- Setting end positions



**Warning!**



**Important safety instructions!**  
Observe the following instructions.

**Risk of injury due to electrocution.**  
The connections to the 230 V mains **must** be made by authorised specialist personnel.

Check the system (roller shutter) regularly for wear or damage.

The regulations of the local energy supply company as well as the regulations for wet and damp rooms according to VDE 0100 must be followed when making the connections.

Only use unmodified original **elero** electrical parts. Keep people away from the system until it is stationary.

When working on the system (servicing, cleaning windows etc.), always disconnect it from the mains supply.

**Check the following before installation:**

- The drive is only capable of operation as installed.
- Only perform connecting work with the power turned off.
- The blind must be attached to the winding shaft.
- The profile tube must have sufficient clearance from the motor tube.
- Make sure there is sufficient axial play (1–2 mm)

**Installation in profile tubes**

Ⓐ Push drive with relevant adapter and limit switch into the profile tube.

Protect the motor cable in order to avoid it brushing against the roller shutter. Avoid kinking the cable.

Ⓑ Secure the counterpart support to prevent axial movement, e.g. screw or rivet on idler.

Secure the drive axially in the support.

Ⓒ Attach the blind to the shaft!

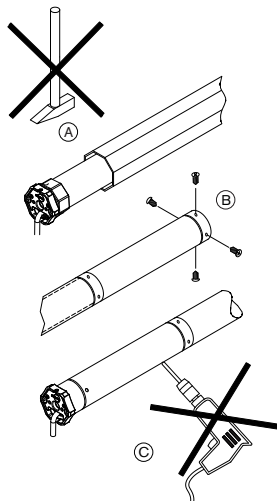

**Warning!**



**Risk of injury due to electrocution.**

Do not drill in the area of the motor!

**Installation**



**Warning!**

**Observe the following installation instructions!**

- The drive must be fixed in such a way that it does not endanger personnel.
- Before installing the drive, all lines and equipment, which are not required for operation, must be removed from the site.
- During installation, during operation and when work is carried out on the system, the option to separate all three poles from the mains must always exist (Hirschmann connector and Hirschmann coupling or a two-pole switch with minimum 3 mm contact gap or all-pole main switch).
- **Parallel switching only with sequencing relay.**
- If the drive is controlled by a switch with OFF pre-setting (dead man's button), the momentary contact switch must be fitted at a height of more than 1.50 m and separated from the moving parts. The travel range of the systems must always be visible during operation.
- Moving parts in a drive, which are below 2.5 m, must be guarded.
- Set torque and set operating time must be adapted to the requirements of the product which is driven. Please note the technical data on the type plate.
- Please note that with this drive (type M motor) the smallest internal tube diameter corresponds with 46 mm.
- The drive must be installed so that it cannot get wet.
- Do not install drives in surroundings which are at risk of explosion or in mobile appliances (e.g. motor vehicles).
- Keep children away from the (remote) control unit.

**Remove of the motor cable plug**



**Warning!**



**Risk of injury due to electrocution.**

When the motor cable plug is removed the supply line **must** be volt free.

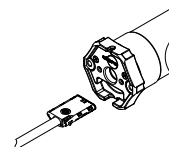

Delivery condition

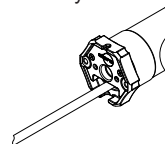

Remove plug

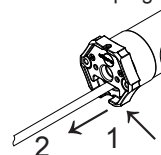

Insert plug

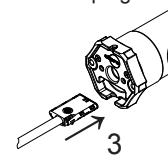

**Remove the motor cable plug**

Switch off voltage supply.

1. Press locking mechanism on the plug towards the cable using a screwdriver.
2. Pull out the plug.

**Insert the motor cable plug**

3. Switch off voltage supply. Insert plug until locking mechanism engages.

# Connection/Installation/Commissioning

## Types of installation

Different types of installation are possible::

Type of installation	Possible with
1. Fixed upper stop lower stop freely adjustable	T-strap, tapes, belt, limit plugs, angle bracket
2. Fixed upper and lower stop	Anti push-up device, limit plugs, angle bracket
3. Upper stop freely adjustable fixed lower stop	Anti push-up device

## Connection example, RoISmart M-K Tubular Motor 230 V/50 Hz

### Note:

The motor controls in up/down direction must be locked against each other.

A reversing delay of at least 0,5 sec. must be ensured.

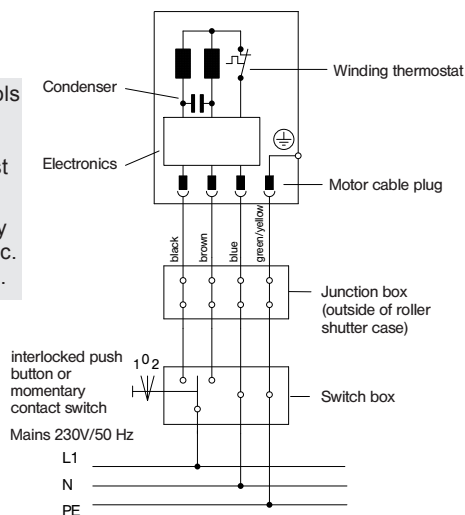

**Note:** Parallel switching only possible with sequencing relay.

## Start up

**Please note:** The RevoLine RoISmart M-K requires a **defined limit stop** (upper or lower limit position). For free programming of both positions, please select a RevoLine RoITop.

**Note:** The drive is in commissioning mode when the roller shutters are delivered.

## Assembly cable connection

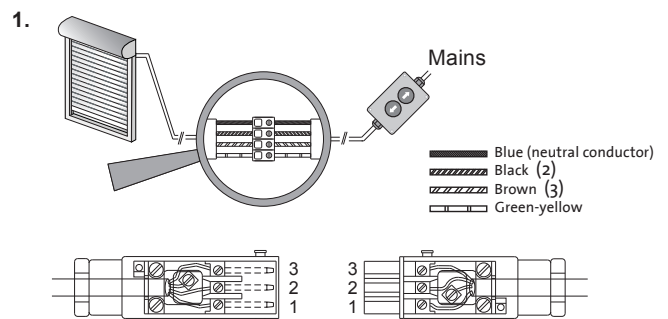

2. Switch on mains.

You can now set the end positions with the assembly cable.

**Please note:** Press the travel key until the drive signals the transition into the programming mode, by a short automatic STOP. You can now program the end positions.

**Note:** The blind protection system is only adapted to the blind after a complete, uninterrupted upwards and downwards travel.

# End position setting

## Installation Method 1: Fixed upper stop/ lower stop freely adjustable

### Installation Method 1: Fixed upper stop/lower stop freely adjustable

**Note:** Ensure that the equipment is correctly connected.

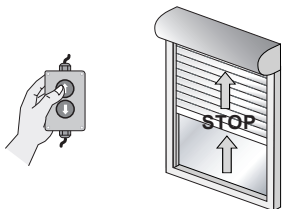

1. Move the blind up to approx. 5 cm before the upper limit stop.  
The drive starts up slowly with a short STOP.

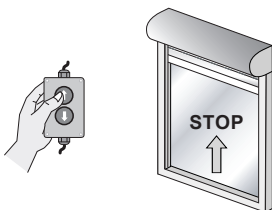

2. Press the **UP** momentary contact switch again.  
Approach the upper limit stop.  
The drive switches off automatically when it reaches the limit stop.

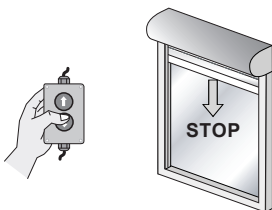

3. Press the **DOWN** momentary contact switch until the drive stops automatically.  
The upper limit stop is programmed.

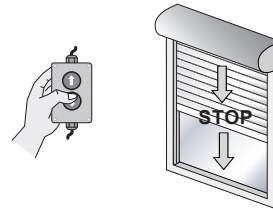

4. Press the **DOWN** momentary contact switch again.  
Move the blind down until it is a short distance above the desired lower limit stop.  
The drive starts up slowly with a short STOP.

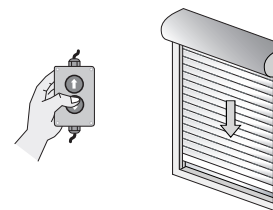

5. Travel to the desired lower limit stop.  
It is possible to make corrections using the momentary contact switches.

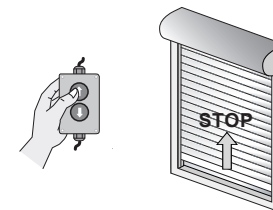

6. Press the **UP** momentary contact switch until the drive stops automatically.  
The lower limit has been set.

Setting of the end positions is now complete.

# End position setting

## Installation Method 2: Fixed upper and lower stop

### Installation Method 2: Fixed upper and lower stop

**Note:** Ensure that the equipment is correctly connected.

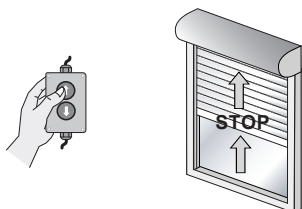

1. Move the blind up to approx. 5 cm before the upper limit stop. The drive starts up slowly with a short STOP.

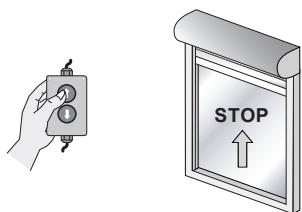

2. Press the **UP** momentary contact switch again. Approach the upper limit stop. The drive switches off automatically when it reaches the limit stop.

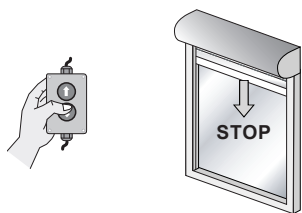

3. Press the **DOWN** momentary contact switch until the drive stops automatically. The upper limit stop is programmed.

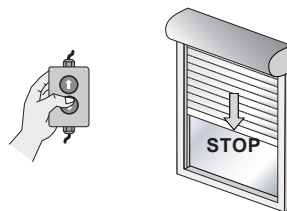

4. Press the **DOWN** momentary contact switch again. Run the blind until shortly before the lower limit stop. The drive starts up slowly with a short STOP.

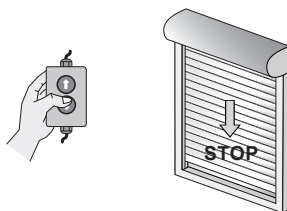

5. Travel slowly to the lower limit stop. The drive switches off automatically when it reaches the limit stop.

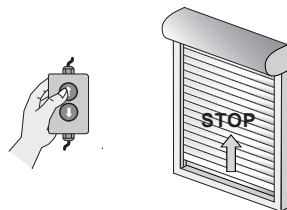

6. Press the **UP** momentary contact switch until the drive stops automatically. The lower limit has been set.

Setting of the end positions is now complete.

# End position setting

## Installation Method 3: Upper stop freely adjustable/ fixed lower stop

### Installation Method 3: Upper stop freely adjustable/ fixed lower stop

**Note:** Ensure that the equipment is correctly connected.

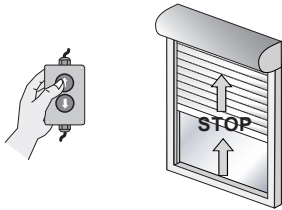

1. Move the blind up to approx. 5 cm before the desired upper limit stop.  
The drive starts up slowly with a short STOP.

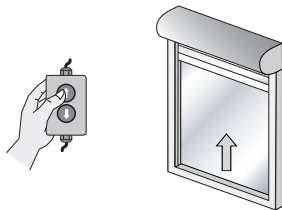

2. Press the **UP** momentary contact switch again.  
Go to the desired upper end position.  
It is possible to make corrections using the momentary contact switches.

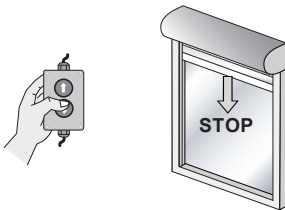

3. Press the **DOWN** momentary contact switch until the drive stops automatically.  
The upper limit stop is programmed.

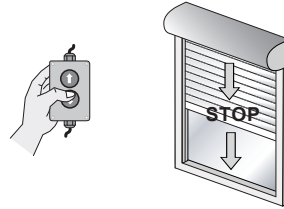

4. Press the **DOWN** momentary contact switch again.  
Run the blind until shortly before the lower limit stop.  
The drive starts up slowly with a short STOP.

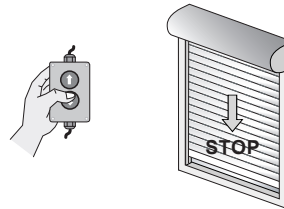

5. Approach the lower limit stop.  
The drive switches off automatically when it reaches the limit stop.

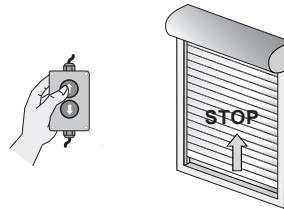

6. Press the **UP** momentary contact switch until the drive stops automatically.  
The lower limit has been set.

Setting of the end positions is now complete.

# Changing/Deleting the limit positions

## Changing/Deleting the limit positions

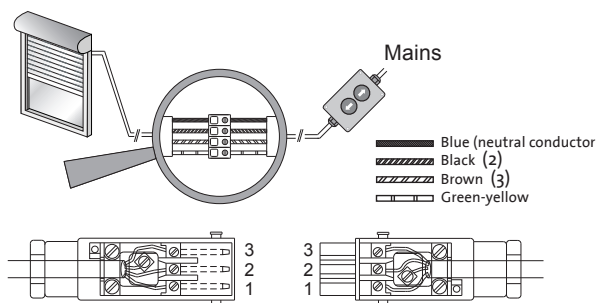

1. Switch on mains.

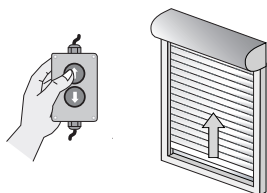

2. Move the blind to an intermediate position.

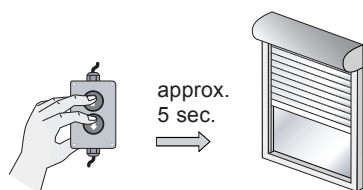

3. Press both momentary contact switches on the assembly cable **simultaneously**.

The drive issues a weak acoustic signal after 5 sec.

Deletion of the limit positions is complete.

# Troubleshooting

## Troubleshooting

Fault	Possible cause	Remedy
• Drive stops during travel	• Limit positions are not set	• Set limit positions
• Drive stops after short travel	• End position programmed • Roller shutter stiff	• Set second limit position • Check smooth running of the roller shutter
• Drive does not react to travel commands	• No power supply • Thermostat has triggered	• Check mains voltage • Allow drive to cool down
• Drive runs only in one direction	• Faulty connection	• Check connection
• Drive does not learn in limit positions	• Random travel before actual limit position setting • Travel to limit position/stop too short	• Delete limit positions Re-programme limit positions • Drive has to travel to short STOP

## EC Declaration of conformity

# EC DECLARATION OF CONFORMITY

We hereby declare that the following mentioned product/s meet/s the **Machinery Directive 2006/42/EC**.

Product designation: **Tubular Drive**

- RolTop S all versions
- RolTop M all versions
- RolTop L all versions
- RolSmart M all versions

Description: Actuator for shutters

The conformity of the above mentioned products with the relevant health and safety requirements is taken into account by the following directives and standards:

- EMC Directive 2004/108/EC
- Low Voltage Directive 2006/95/EC  
DIN EN 60335-2-97 (VDE 0700-97):2009
- DIN EN 14202:2004

Beuren, 31.05.2012



Ralph Trost  
-CE Manager-, -Representative documentation -