



After the venetian blind motor has been installed, attach these instructions to the cable for the use of the electrician.

Advice: The drive may only be operated with an safety cut-out.

Mounting instructions

Mounting of the safety cut-out „right hand installation“

Remove label on the bottom side of the limit switch housing and insert the safety cut-out with **orange** or **black** cap in the openings and engage it in such a way that the orange or black pressure pin points towards the side of the orange adjustment push-button **UP**. If the supplied safety cut-out cannot be used, e.g. due to lack of space, then the label must not be removed since it protects the inside of the limit switch against dirt.

Please check the function of the safety cut-out. Incorrect installation may lead to damage.

If the safety cut-out is not long enough, it can be extended by 10 mm at a time with the safety cut-out extension (article number 16 101.4501). (Maximum of 3 safety cut-out extensions can be plugged on).

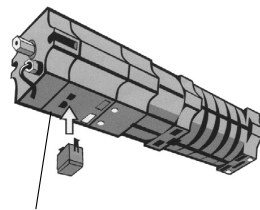

Insert the blade of a small flat screwdriver into one of the grooves on the orange cover and by pressing the blade towards the middle of the safety cut-out, lever off the cover. Clip on the extension and then clip on the cover again.

Mounting of the safety cut-out „left hand installation“ (special Accessory)

When installing the JA drive as a left-hand system the arrangement of the microswitches inside the limit switch housing automatically swaps over the **UP** and **DOWN** movements.

This means that the safety cut-out with the white cap (article number 26 200.1101) must be used.

This safety cut-out must be inserted and clipped into the openings of the limit switch housing so that the „white“ pressure pin points to the side of the „white“ adjustment push button. The label L provided with the directional advice, should then be stuck over the existing label on the front.



Mounting of the QuickSnap coupling for JA

1. Apply coupling at an angle whilst observing the position of the coupling with respect to the shaft: The stop spring should slide on the upper surface of the hexagonal shaft.
2. Push coupling a little further until the spring audibly latches into the groove. (Click).
3. If the groove is covered by a bearing or lockwasher, the hexagonal shaft can be correspondingly pushed back until the coupling spring latches into place.
4. By pulling it by jerks check that the coupling is securely seated.

Dismantling of the QuickSnap coupling for JA

Do not forcibly remove the coupling.

1. Lift up the motor coupling retaining spring on the shaft with a small screwdriver.
2. Pull off the coupling.

Installation in headpiece

Installation instructions:

- Install drive without restraint, in **correct position (safety cut-out showing downwards)**, and properly aligned with the shafts in the venetian blind head.
- Impacts (e.g. hammer blows) are not permitted on drive, shaft or coupling.
- The axle height of the drive is 27.5 mm. See JA accessories for dampers for different bearing blocks axle heights.
- Make sure that the shaft is not radially loaded.
- Make electrical connection with installation cable and check the turning direction of the drive shaft according to the direction advice on the front of the limit switch housing. Travel to the lower end position again with the **DOWN** pushbutton.
- Couple drive to shaft.

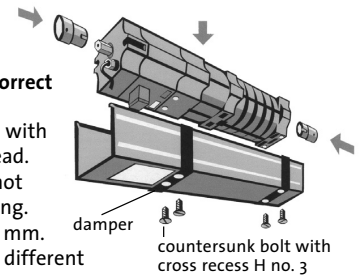

Advice:

- Valid only with right hand installation.
- In the case of left hand installation the colour assignment is exactly reversed.

Setting instructions:

Venetian blind drives are supplied from the factory already set to the lower end position. Connect installation cable to venetian blind drive.

Setting the upper end position:

- Move venetian blind upwards with the corresponding push button.
- Press in the orange adjustment button while it is moving up and hold it in for **at least 5 seconds** (adjustment button stays latched in).

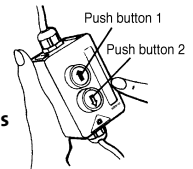

Advice:

This must have taken place at latest 0.5 m before reaching the end position. After pressing the adjustment button it must stay latched in.

- With the help of the installation cable travel directly to the upper end position (fine adjustment by means of inching operation with the installation cable).
- By changing the direction of travel the adjustment button is automatically unlatched and the upper end position is then set.

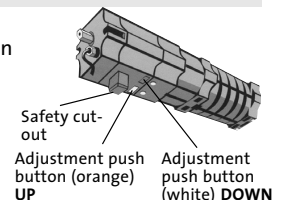

Setting the lower end position:

It is not normally necessary to set the lower end position since the venetian blind drives are set to the lower end position in the factory. If it is necessary however the setting takes place in the same way as for the upper end position.

- Move venetian blind downwards with the corresponding push button.
- Simultaneously press the white adjustment button and hold it down for **at least 5 seconds**.

Advice:

This must have taken place at latest 0.5 m before reaching the end position. After pressing the adjustment button it must stay latched in.

- With the help of the installation cable travel directly to the lower end position (fine adjustment by means of inching operation with the installation cable).
- By changing the direction of travel the adjustment button is automatically unlatched and the lower end position is then set.

Readjustments:

If the respective end position is not accurately set or if the end positions have changed due to changed winding behaviour of the venetian blind, then the end positions will have to be reset as described above.

With the help of the installation cable the venetian blind should be moved back to about 0.5 m before the desired end position.

The limit switch range is 85 revolutions of the shaft.

JA Venetian Blind Motors



Important safety advices! Observe the following instructions.

Risk of injury due to electrocution.

The connections to the 120 V mains **must** be made by authorised specialist personnel.

The regulations of the local energy supply company as well as the regulations for wet and damp rooms according to NFPA must be followed when making the connections.

Only use unmodified original **elero** electrical parts.

This drive is suitable only for interior and exterior venetian blinds. For other applications please contact the manufacturer.

Keep people away from the system until it is stationary.

When working on the system (servicing, cleaning windows etc.), always separate it from the mains supply.

If the venetian blind motor is fitted as part of a machine or any other installation, the user has to make sure that the EMC regulations continue to be observed.

elero venetian blind motors are approved:

- UL 1004 electric motors
- UL 2111 overheating protection for motors
- CSA C22.2 No. 100 motors and generators
- CSA C22.2 No. 77 overheating protection

Connection of 2 or more motors is possible only

- with a central or decentral control system or
- with a multipin interlocking venetian blind switch. (send for the according elero control system catalogue).

Assembly

- The drive must be fixed in such a way that it is not a danger to personnel.
- Before installing the drive, all lines and equipment, which are not required for operation, must be removed from the site.
- Before the drive is installed, make sure that the fuses are switched off.
- During installation, provision must be made for an all-pole disconnection from the mains supply, e.g. with male Hirschmann plug, Item No. 23 846.0001, and female Hirschmann plug, Item No. 13 701.5301, a with at two-pin interlocked switch with at least 3 mm contact opening distance or all-pole mains switch.
- If the drive is controlled by a switch with OFF pre-setting (dead man's button), the pushbutton must be fitted at a height of more than 1.50 m and separated from the moving parts.
The travel range of the systems must always be visible during operation.
- Moving parts in a drive, which are below 2,5 m, must be guarded.
- For drives supplied without a driven part the design torque and the design operating time must agree with the properties of the driven parts.
Please note the technical data on the type plate.
- When installing JA drives in systems, devices or machines the installer must ensure that electromagnetic compatibility is maintained.
- The system should be checked at regular intervals for wear or damage.
- The drive may only be installed in such a way that it is not directly subject to the influence of the weather.

- Note the technical data for the motor.
- Keep children away from the controller and remote controller.
- When installing JA drives in systems, devices or machines the installer must ensure that electromagnetic compatibility is maintained.
- If the drive unit is operated by a pushbutton, it should be fitted in a position from where the window can be seen and at a height of not less than 1.5 m.
- Do not install drives in surroundings which are at risk of explosion or in mobile appliances (e.g. motor vehicles).

Advice

The guarantee will lapse if the electrical connections are incorrect, if the installation work has been carried out improperly or if repairs, interventions and changes have been made by unauthorised people!

Connection Example

1 venetian blind motor

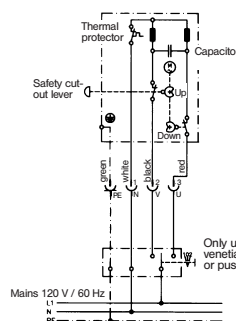

2 venetian blind motors

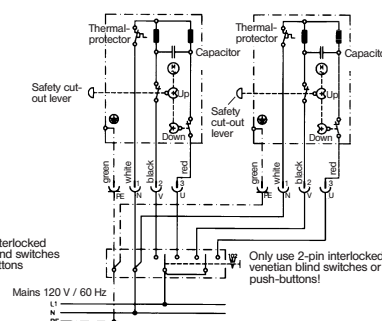

Do not use switches, push-button, switching systems which allow to give an "Up" and "Down" command at the same time.

When reversing direction of travel, ensure a volt free period of at least 0,5 sec.



Warning!

Do not connect 2 or more motors in parallel! Due to feedback voltage the limit switches could be damaged!

